



Aerospace Bellows

OVERVIEW

Whether flight critical, land-based or offshore, BellowsTech manufactures custom edge welded bellows for aerospace, military and naval applications. With a variety of materials, sizes and customization, BellowsTech can provide a solution that fits the size, weight, pressure, temperature, and corrosion resistance properties to fulfill the application needs.



SPECIFICATIONS

Material	Stainless Steels, Alloys, & Titanium available. Consult Factory.
Thickness	From 0.002" and up every 0.001"
Standard Leak Rate	From $<1 \times 10^{-9}$ std CC He/sec (check material)
Size Ranges	
Outside Diameter	0.396" (10.058mm) to 26" (660mm)
Inside Diameter	0.2" (5.08mm) to 25.5" (648mm)
Shapes	Round; Non-Round available. Contact Factory.
Length	up to 96 inches (244cm)

Outlines

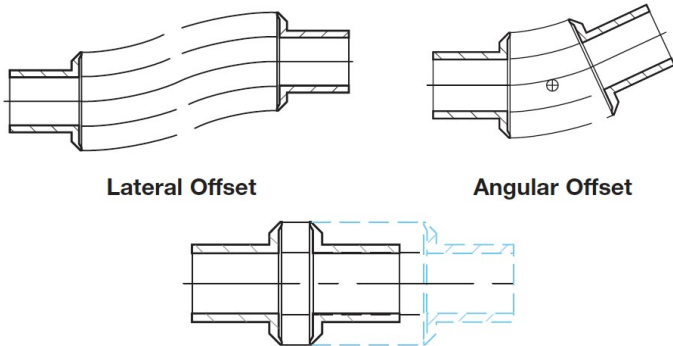

Axial Compression and Extension

WHY CHOOSE BELLOWSTECH?

Work with the best engineers in the industry to develop a custom bellows

ISO 9001 - March 2011 (AS9100 Compliant)

Superior Performance

Excellent Response Time

Competitive Pricing

POPULAR PRODUCTS

Volume Compensators

Actuators

Titanium Bellows

Inconel Bellows

Why Choose Edge Welded Bellows?

Of the three major metal bellows technologies, edge welded metal bellows have the highest stroke length, reaching 90% of its free length. This flexibility allows for increased expansion and contraction of the bellows. Edge welded bellows can be exposed to extreme temperatures and media with a wide selection of materials. Both the inside and outside of the bellows can be exposed liquids and gases. Edge welded metal bellows also have a high cycle life to produce repeatable results and round or square shapes.